

MotoFit

Force control assembly tool

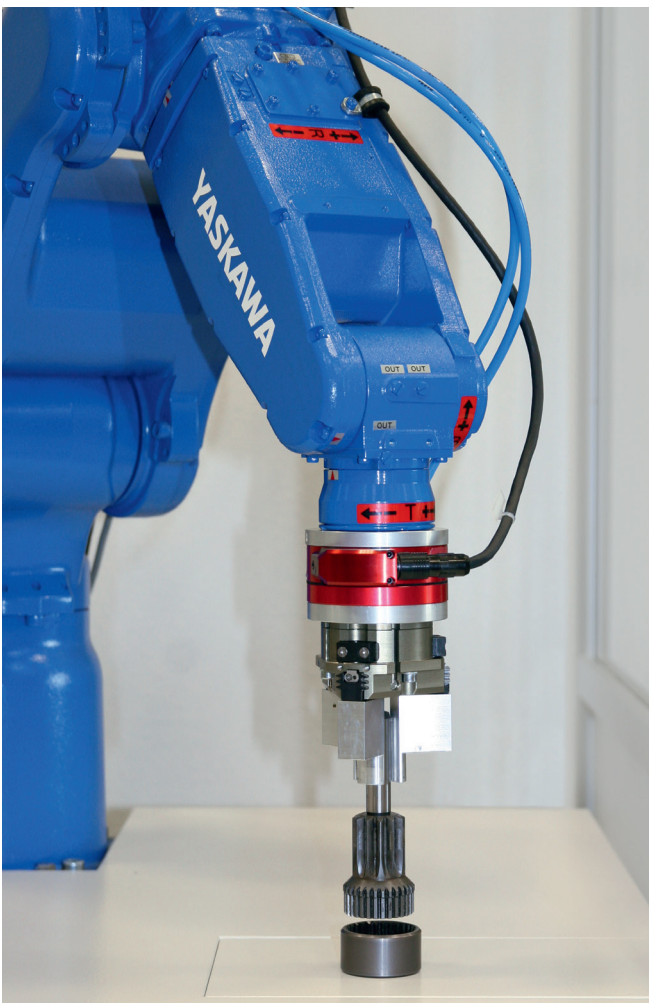

KEY BENEFITS

- High tolerance assembly
- Built-in programming tools
- Improved reliability

MotoFit alters the robot's position based on the force encountered to align or assemble parts. (During normal robot operation, the robot is setup for positional control. It moves to or retains position even when external forces are applied, provided that forces do not exceed limits that would cause an error.)

The six-axis force sensor detects three translational forces and three axial moments to detect external forces during job execution. Three operations (touching, fitting and inserting) are combined to provide automatic precision fits of mating surfaces of 10 –100 μm .

High-speed fits up to 20 mm deep with h7/H7 tolerance can typically be done in five seconds. Also the force sensing control parameters can be taught quickly without unique skills. Its hole position detection and snag prevention increase reliability.

The Engineering Support Tool (EST), a PC application, is used for sensor setup and job creation. It supports one or two robots, up to 24 force files, and robot or tool coordinate systems. Therefore jobs can be edited on the controller if needed.

Features

- Ability to enable or disable each translational force or axial moment
- Helpful graphics for troubleshooting and setup
- Step-by-step instructions
- Ideal for precision part assembly applications including drive train components, seats, electronics, battery assembly and nondestructive testing

Components

- Six-axis sensor (200 N (V) or 1000 N (H or V))
- High-speed communication board
- Power supply box
- Robot-specific mounting flange adapter
- Engineering Support Tool software with interface panel software

200 N Sensor

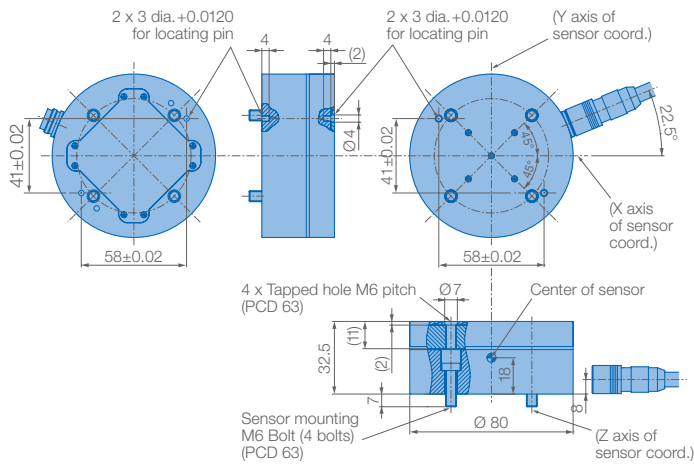

1000 N Sensor

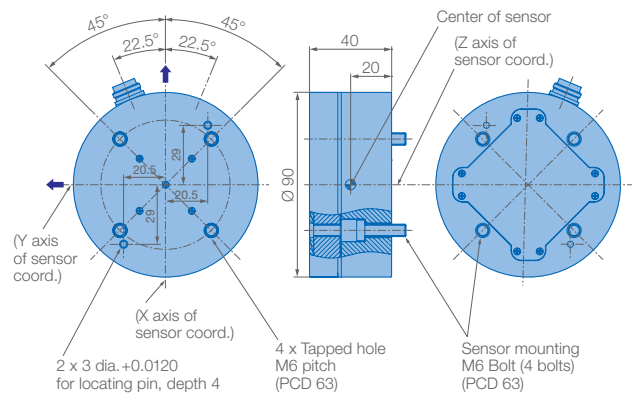

Specifications		
Operation functions	Touching function (dedicated INFORM language)	
	Fitting function (dedicated INFORM language)	
	Inserting function (dedicated INFORM language)	
Functions that increase reliability	Search function, snagging prevention function	
Teaching method	Semi-automatic adjustment method using Engineering Support Tool for MotoFit functions; runs on customer's personal computer	
6-axis force sensor	Dedicated sensor specified by YASKAWA Electric (provided as an accessory at delivery); two types with rating of 200N and 1000N	
Conditions for applicable workpieces	Geometry	Cylindrical
	Fit clearance	h7/H7 or greater; clearance must be at least 10 µm
	Chamfer	C 0.1 or more
	Fit depth	20 mm or less
	Initial position error	± 1 mm or less
Other functions	Force-tracking function (dedicated macro command)	
	Pressing function (dedicated macro command)	
	Force-sensing function (dedicated macro command)	
Support for MotoPlus	Force control service API (must be specified as option)	

		6-axis sensor rated 200 N	6-axis sensor rated 1000 N*
Rated load	Fx, Fy, Fz	200 N	1000 N
	Mx, My, Mz	4 Nm	30 Nm
Load protection stopper to work	Fx, Fy, Fz	1000 N	5000 N
	*Mx, My, Mz	6 Nm	50 Nm
Resolution		0.024 N	0.12 N
Supply voltage		24 V DC	24 V DC
Sampling frequency		2 kHz	2 kHz
Dustproof / Waterproof		IP65	IP65
Inductive noise immunity		1500 V	1500 V
Size [mm]		w 80 x H 32.5	w 90 x H 40
Weight [g]		360	580

Robot compatibility

DX200 models: MH5SII, MH5LSII, MH12, MH24
 FS100 models: MH5F, MH5LF, MH6F, MH6F-10, MH12F

Ambient conditions

- Ambient operating temperature: 0 to +40° C
- Less moisture and dry (humidity: 20 to 80 % RH, non-condensing)
- Free from dust, dirt, oil mist, and water drop
- Free from corrosive gases or liquid, or explosive gases or liquid
- Free from excessive impact or vibration (4.9 m/s² [0.5 G] or less)
- Free from large electrical noise (TIG welder, etc.)
- The flatness for installation is 0.5 mm or less

* Installation of MotoFit sensor may change robot range of motion. Installation of MotoFit sensor must be considered when evaluating robot wrist suitability for a given project.